

HAND TOOLS

SURFACE

PREPARATION

FINISHING

SUPPLIES

HAND TOOLS



NO.	PART NO.	DESCRIPTION.
A	12800	1 1/4" Flexble Scraper & Putty Knife
B	12810	1 1/4" Stiff Scraper With Chisel Edge
C	12820	Flexible Scraper & Putty Knife

HAND TOOLS



NO.	PART NO.	DESCRIPTION.
A	13800	Extra Long Hooker
B	13900	Mini Pick, Hook & Scribe Set
C	14000	Punch All

HAND TOOLS



NO.	PART NO.	DESCRIPTION.
A	16900	Sheet Metal Snip
B	17280	Spray Gun Cleaning Kit
C	G5525	Mini Spray Gun Cleaning Kit

HAND TOOLS



NO.	PART NO.	DESCRIPTION.
A	G5526	Brush, Spray Gun Cleaning - Large
B	G5523	Brush, Wire GP Hand
C	G5528	Brush, Cleaning and Application - Nylon
D	1715000	Nylon Shop Brush Sets - 70m, 50mm & 30mm (Pkt 3)

HAND TOOLS

HAND TOOLS

- The big easy tool kit enables you to activate the door handle, manual lock button, or electric lock button on more than 98% of all cars and trucks with no danger of airbag activation or disconnected door linkages.

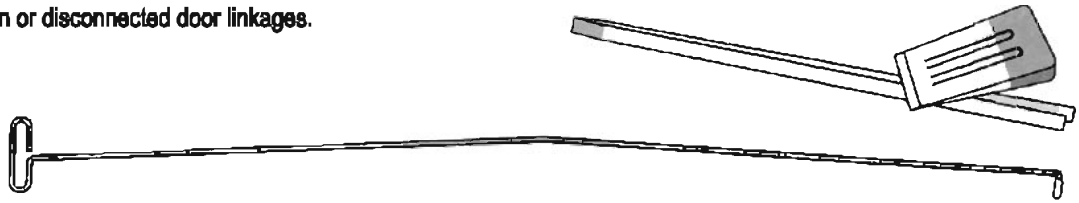

PART NO.	DESCRIPTION.
32900	The Big Easy Lock Out Tool Kit

HAND TOOLS

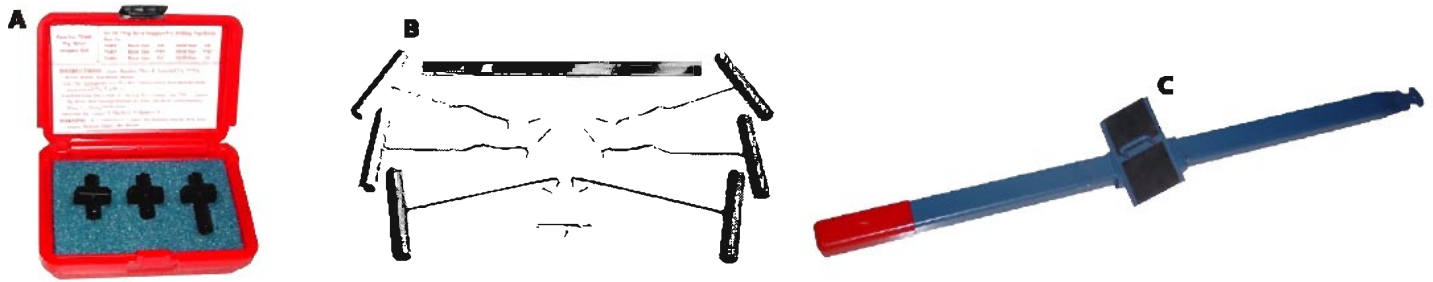

NO.	PART NO.	DESCRIPTION.
A	71400	Pop Rivet Stopper Kit
B	81900	Pull Rod Kit
C	82150	Door Alignment Tool

HAND TOOLS

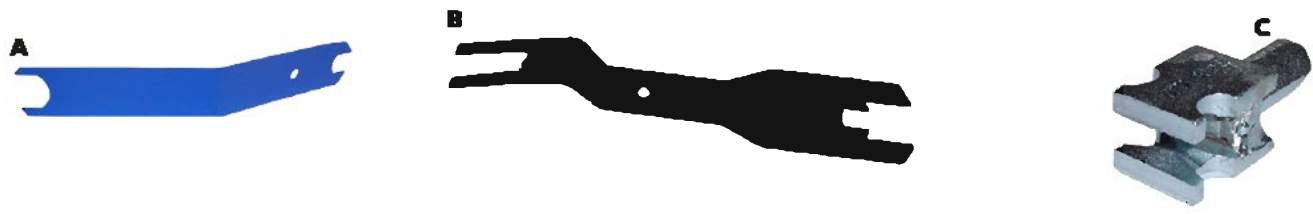

NO.	PART NO.	DESCRIPTION.
A	87600	Door Handle Clip Remover
B	87615	Universal Clip Remover
C	87625	Torsion Spring Tool

HAND TOOLS



NO.	PART NO.	DESCRIPTION.
A	87650	Trim Pad Removal Tool
B	HAP 220	Mould Release Tool
C	17000	Door Jammer

HAND TOOLS



NO.	PART NO.	DESCRIPTION.
A	87700	Jiggler GMH
B	87800	Jiggler Ford
C	HAP 218-1	Universal 10 In 1 Tool

HAND TOOLS



NO.	PART NO.	DESCRIPTION.
A	91625	Panel Crimper
B	94800	Abrasive Disc Trimmer
C	94850	Tune Up Kit For Abrasive Disc Trimmer

HAND TOOLS



NO.	PART NO.	DESCRIPTION.
A	LST100	Locking Strip Tool
B	21720	Sure Grip Trim Pliers
C	23230	Plug Weld Pliers

HAND TOOLS

- For high crown work and finishing.
- Drop forged hammer designed to reduce time needed to fold the flange on door skins.
- Can also be used to reach the inner panels on vehicles.
- Use with door skin dolly part no. 88160.



- Thick rubber absorbs shock and provides cushioning effect.
- Great for applying door skins.
- Weighted hard rubber to match weight of hammer.
- Moves the metal rather than scratching it.
- Use with door skin hammer see part no. 89350.

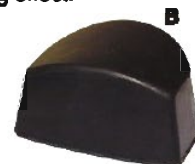

NO.	PART NO.	DESCRIPTION.
A	89350	Door Skin Hammer
B	88160	Door Skin Dolly

HAND TOOLS

HAND TOOLS

- A perfect and simple measuring tool for all contoured surfaces
- Robust design, made from high quality plastic.
- Double sided, both sides can be used.
- 38cm in length with option to lengthen slightly.
- Contour guide includes mm and inches for measurement.
- Built in magnets for easy attachment to metal surfaces.



PART NO.	DESCRIPTION.
A2070KA	The Contour Guide

HAND TOOLS

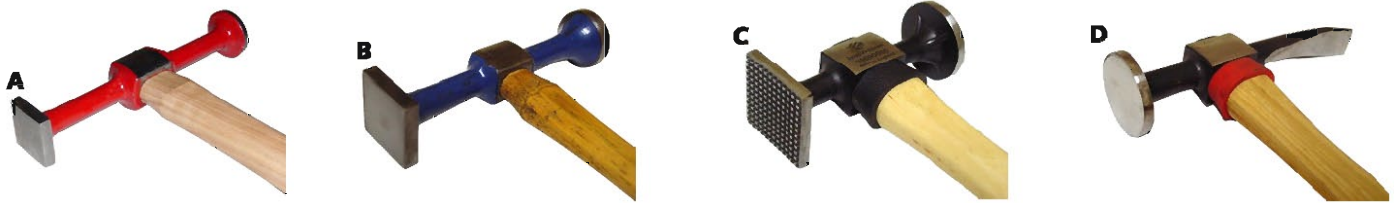

NO.	PART NO.	DESCRIPTION.
A	056300	Panel Beater - Light Dinging Hammer
B	053300	Panel Beater - Heavy Dinging Hammer
C	056900	Panel Beater - Light Shrinking Hammer
D	053700	Panel Beater - Curved Pein and Finishing Hammer

HAND TOOLS

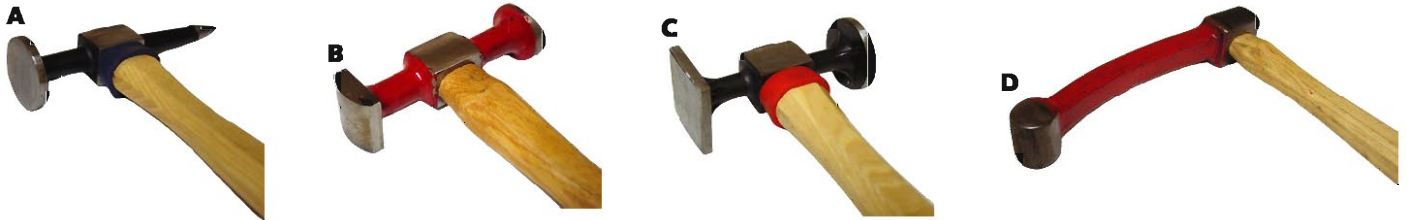

NO.	PART NO.	DESCRIPTION.
A	053000	Panel Beater - Pick & Finishing Hammer
B	053500	Panel Beater - Hickory Hammer
C	056100	Panel Beater - Standard Bumping Hammer
D	057000	Fender Bumping Hammer

HAND TOOLS

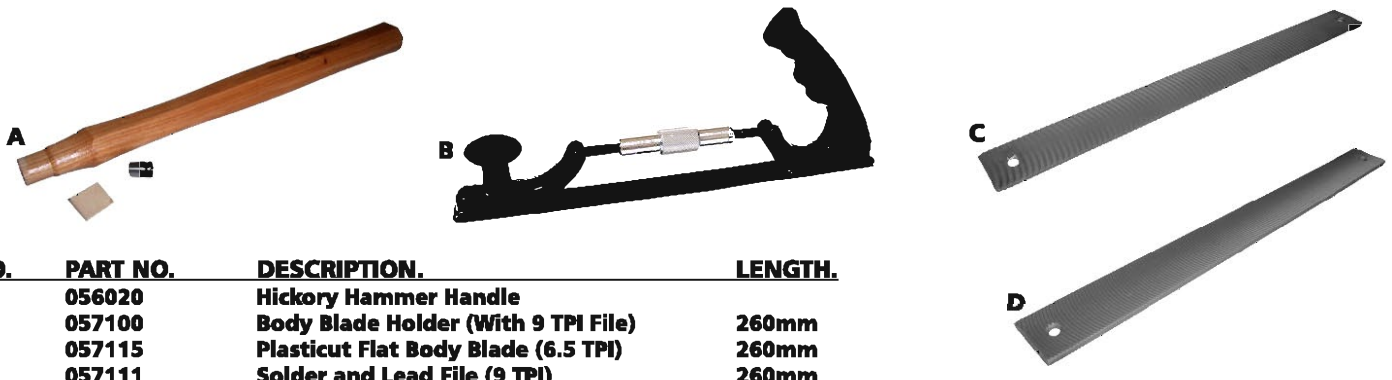

NO.	PART NO.	DESCRIPTION.	LENGTH.
A	056020	Hickory Hammer Handle	
B	057100	Body Blade Holder (With 9 TPI File)	260mm
C	057115	Plasticut Flat Body Blade (6.5 TPI)	260mm
D	057111	Solder and Lead File (9 TPI)	260mm

HAND TOOLS

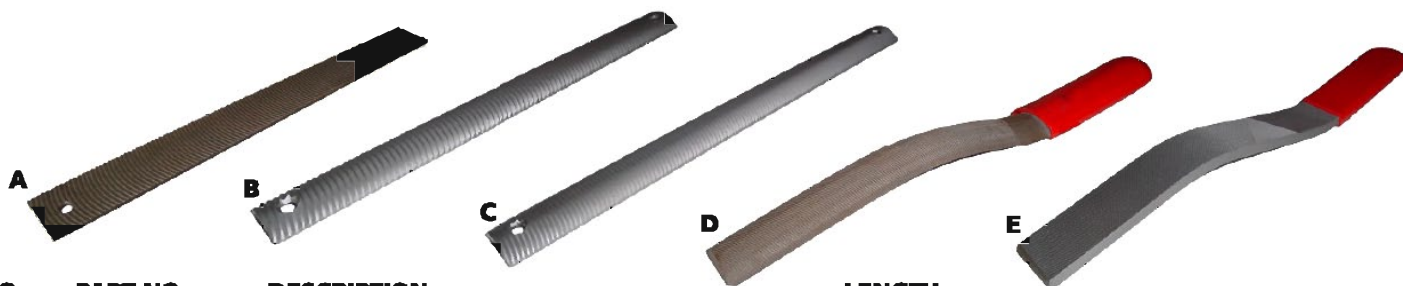

NO.	PART NO.	DESCRIPTION.	LENGTH.
A	057112	Metal Flat Body Blade (13 TPI)	260mm
B	059321	Body Blade (Rigid, 6.5 TPI, Single Sided)	260mm Plasticut Half Round
C	059325	Body Blade (Rigid, 9 TPI, Single Sided)	260mm Half Round
D	059500	Bumping Blade (Half Round)	
E	059400	Bumping Blade (Flat)	

HAND TOOLS

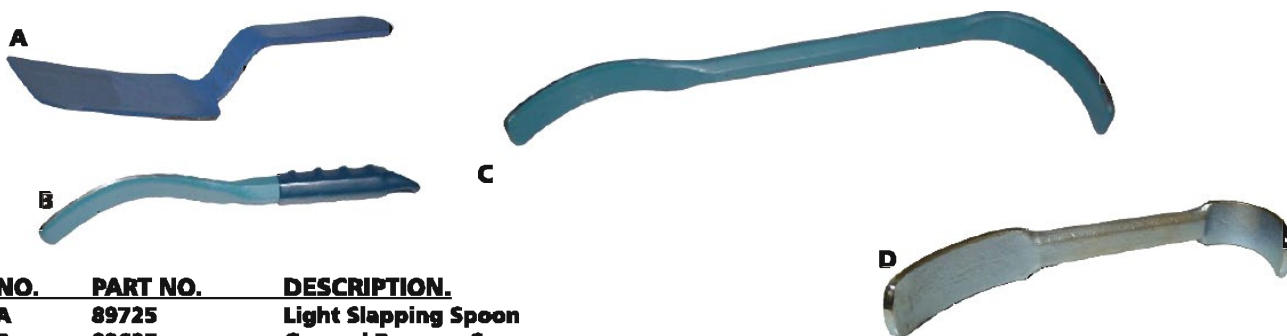

NO.	PART NO.	DESCRIPTION.
A	89725	Light Slapping Spoon
B	89625	General Purpose Spoon
C	89700	Pry & Bump Spoon
D	057400	General Purpose Spoon

HAND TOOLS

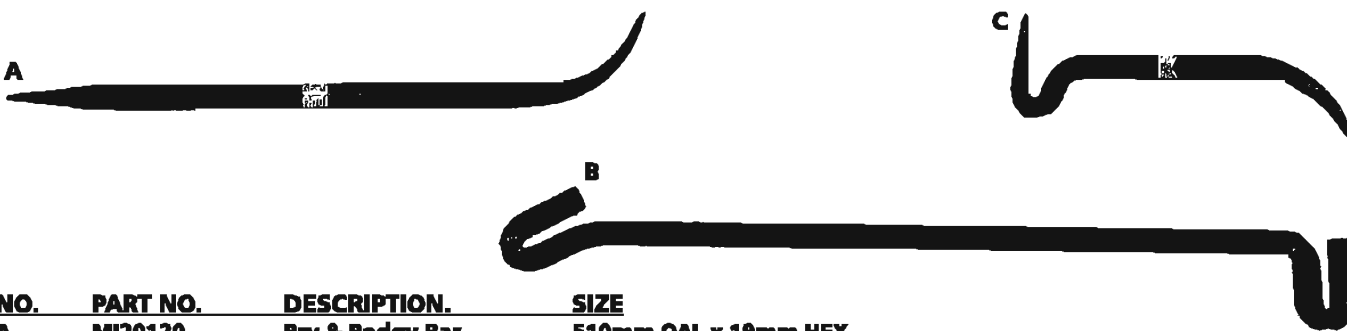

NO.	PART NO.	DESCRIPTION.	SIZE
A	MI20120	Pry & Podgy Bar	510mm OAL x 19mm HEX
B	MI20110	Pry Spoon	280mm OAL x 19mm HEX
C	MI20100	Bending Bar	800mm OAL X 19mm HEX

HAND TOOLS

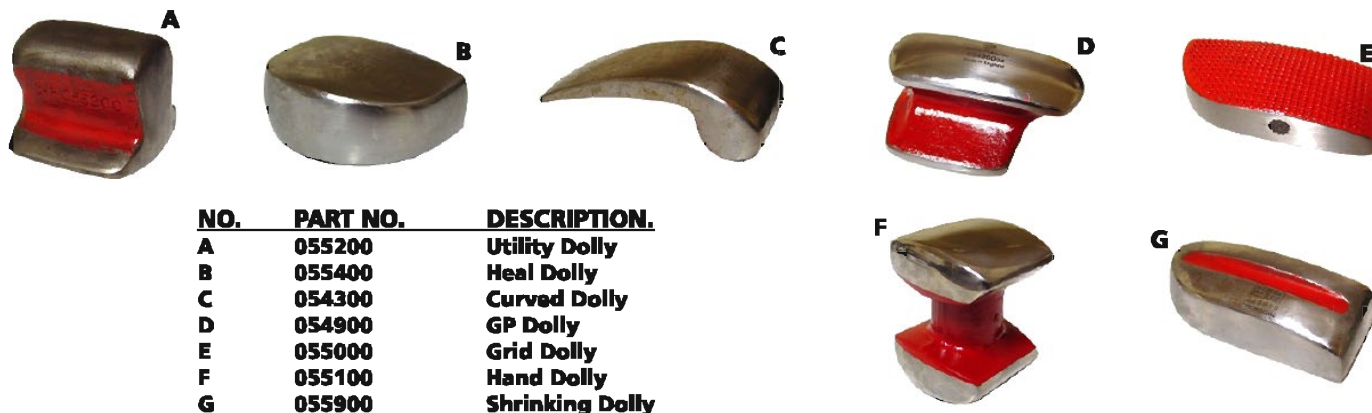

NO.	PART NO.	DESCRIPTION.
A	055200	Utility Dolly
B	055400	Heal Dolly
C	054300	Curved Dolly
D	054900	GP Dolly
E	055000	Grid Dolly
F	055100	Hand Dolly
G	055900	Shrinking Dolly

HAND TOOLS

HAND TOOLS

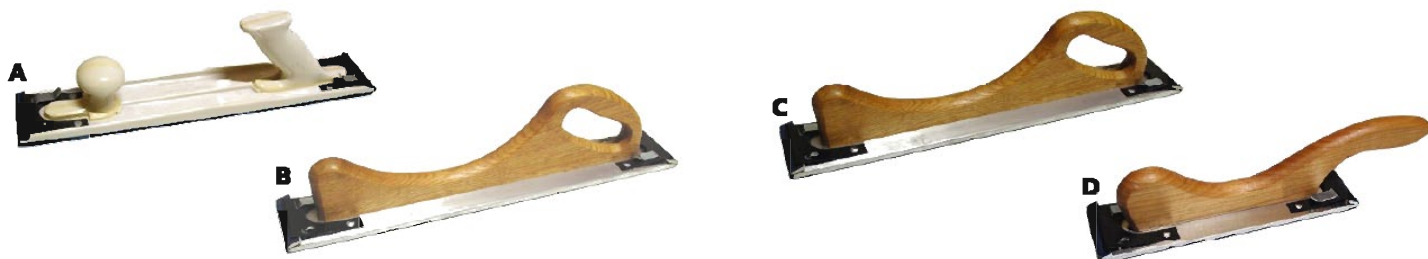

NO.	PART NO.	MODEL	DESCRIPTION.	SUITS PAPER SIZE.
A	5501	PF-16	Speedfile, High Impact Plastic	70mm x 460mm
B	5502	AF-16	Speedfile, Aluminum	70mm x 460mm
C	5507	F-16	Speedfile, Masonite	70mm x 460mm
D	5504	AF-11	Speedfile, Aluminum	70mm x 280mm

HAND TOOLS

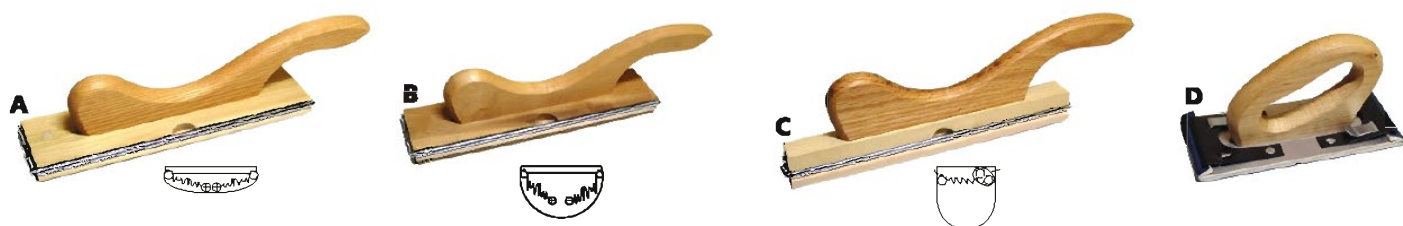

NO.	PART NO.	MODEL	DESCRIPTION.	SUITS PAPER SIZE.
A	5511	C-11	Speedfile, Hardwood, Wide Radius	115mm x 280mm
B	5510	S-11	Speedfile, Hardwood, Medium Radius	100mm x 280mm
C	5512	R-11	Speedfile, Hardwood, Small Radius	77mm x 280mm
D	5506	AF-8	Speedfile, Aluminum	77mm x 203mm

HAND TOOLS



NO.	PART NO.	DESCRIPTION.	SUITS PAPER SIZE.
A	GS110	File Board	70mm x 460mm
B	GS112	File Board	70mm x 280mm
C	GS114	File Board	90mm x 230mm
D	GS116	File Board	115mm x 280mm
E	GS119	Replacement File Board Clips	



HAND TOOLS



NO.	PART NO.	DESCRIPTION.	SUITS PAPER SIZE.
A	GS110H	File Board Hook	70mm x 420mm
B	GS112H	File Board Hook	70mm x 240mm
C	GS114H	File Board Hook	90mm x 190mm
D	GS116H	File Board Hook	115mm x 230mm

HAND TOOLS

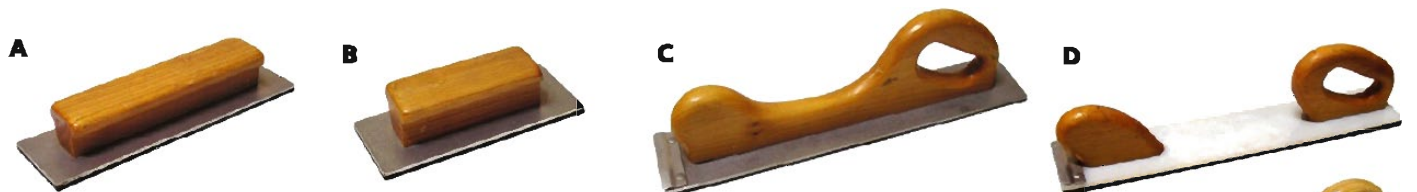

NO.	PART NO.	DESCRIPTION.	SUITS PAPER SIZE.
A	GS113	File Board PSA - No Clips	70mm x 420mm
B	GS115	File Board PSA - No Clips	70mm x 420mm
C	GS117	File Board PSA - No Clips	70mm x 140mm
D	GS118	File Board PSA(Flex) - No Clips	70mm x 240mm
E	GS111	File Board (Economy)	70mm x 460mm

HAND TOOLS

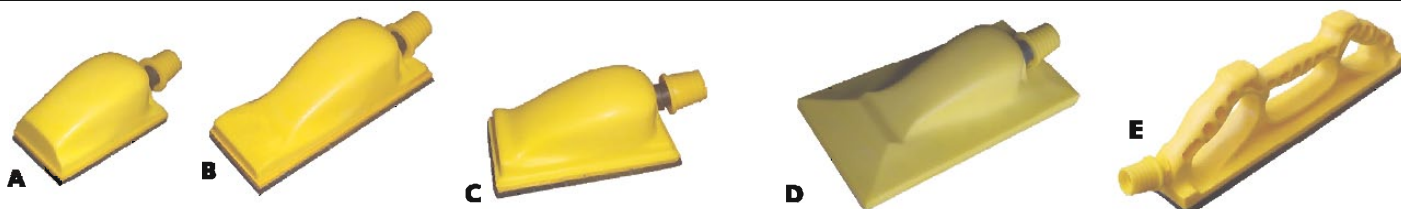

NO.	PART NO.	DESCRIPTION.	SUITS PAPER SIZE.
A	HB1	Dust Free Sanding Block (Velcro)	70mm x 125mm
B	HB2	Dust Free Sanding Block (Velcro)	70mm x 198mm
C	HB3	Dust Free Sanding Board (Velcro)	80mm x 145mm
D	HB4	Dust Free Sanding Board (Velcro)	115mm x 230mm
E	HB5	Dust Free Sanding Board (Velcro)	70mm x 420mm
F	AB59	Handblock Hose and Coupling	20mm I.D. x 1m



HAND TOOLS

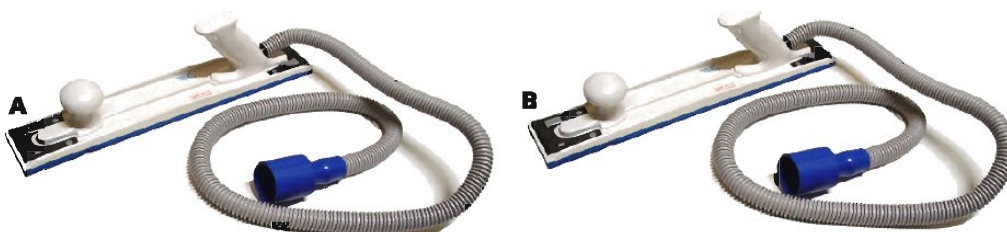

NO.	PART NO.	MODEL.	DESCRIPTION.	SIZE.
A	5540	PF16V	Dust Free Speedfile Board (Std)	70mm x 460mm
B	5540H	PF16VH	Dust Free Speedfile Board (Velcro)	70mm x 420mm

HAND TOOLS



NO.	PART NO.	DESCRIPTION.	SUITS PAPER SIZE.
A	GS100	Colour Sanding Block	70mm x 140mm
B	GS104	Wet/Dry Block	70mm x 140mm
C	GS106	Sanding Block	70mm x 230mm
D	GS108	Sanding Block	70mm x 130mm
E	GS109	Sanding Block With Springs (Kaupp Type)	115mm x 280mm

SCANGRIP pliers manufactured since 1946

Single piece arms. No rivets

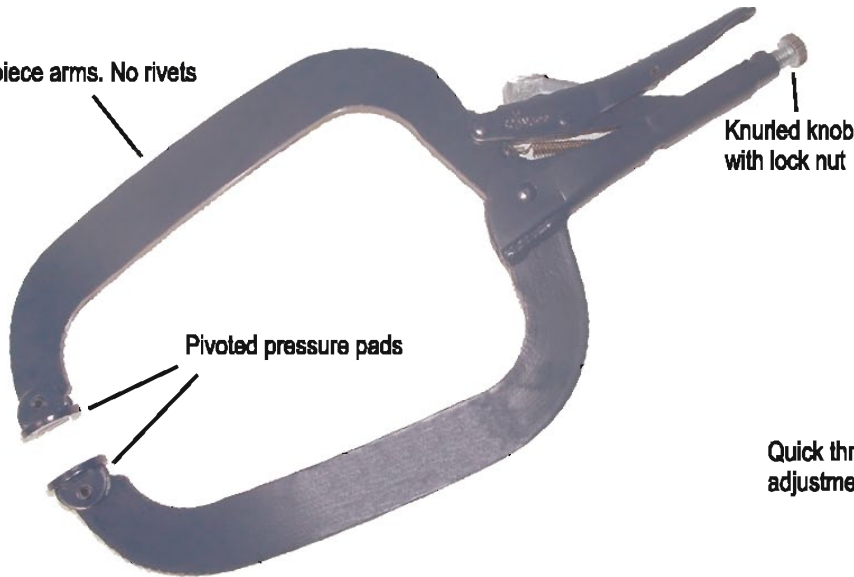

Hardened teeth jaws



Constructed of high-grade heat-treated alloy steel for maximum toughness and durability

SCANGRIP HAND CLAMPS



The Single-Hand Operated Pliers



- General purpose for quick positioning. Curved jaws and hardened teeth allow for excellent grip on round objects, ideal for small thin objects.

PART NO.	No.4
Length:	220mm
Weight:	0.50kg
Max. Span:	0 - 30mm
Min. Span:	0mm flat, eller dia 8mm
Max. Reach:	40mm
Max. Clamp Pressure:	400N
Jaw Width:	16mm



- Forward pointing jaws allow for clamping close to flat surfaces and narrow corners.

PART NO.	No.6
Length:	260mm
Weight:	0.64kg
Max. Span:	80mm
Min. Span:	0mm flat
Max. Reach:	80mm
Jaw Points:	Approx. R = 2mm x Width 10mm
Max. Clamp Pressure:	2500N



- Multi purpose welding clamp with self adjusting pressure pads.

PART NO.	No.7
Length:	280mm
Weight:	0.72kg
Max. Span:	80mm
Min. Span:	0mm
Max. Reach:	80mm
Max. Clamp Pressure:	2500N

SCANGRIP HAND CLAMPS



The Single-Hand Operated Pliers



- Double jawed welding clamp ideal for holding two pieces together, pads distribute pressure evenly providing a better grip on both objects.

PART NO.	No.9
Length:	260mm
Weight:	0.78kg
Max. Span:	60mm
Min. Span:	0mm flat
Max. Reach:	70mm
Int. distance between jaws:	38mm
Max. Clamp Pressure:	1000N



- Space saving clamp with self adjusting pressure pads able to fit into tight corners.

PART NO.	No.14
Length:	280mm
Weight:	0.64kg
Max. Span:	80mm
Min. Span:	0mm
Max. Reach:	85mm
Max. Clamp Pressure:	2500N



- Extra strong wide jaws allow pressure to be applied to the corners first then along the front edge, perfect for bending sheet metal.

PART NO.	No.15
Length:	220mm
Weight:	0.61kg
Max. Span:	15mm dia
Min. Span:	0mm
Max. Reach:	30mm
Jaw Width:	67mm
Max. Clamp Pressure:	3000N



• "Nudge" new spare parts into position and hold them steady for welding. Clamp includes two hardened pointed teeth, positioned offset from each other, one on each jaw.

PART NO. No.18

Length: 220mm
 Weight: 0.52kg
 Max. Clamp Pressure: 2500N



• Features wide arms that reach over and around wide obstacles and grip to the workplace securely. Use when protection of delicate surfaces is needed.

PART NO. No.72

Length: 410mm
 Weight: 1.22kg
 Max. Span: 170mm
 Min. Span: 0mm
 Max. Reach: 210mm
 Max. Clamp Pressure: 1000N

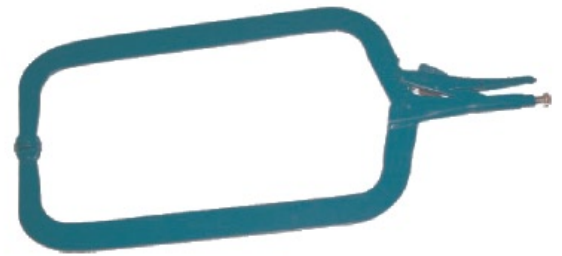

• Same features as clamp No.75, with longer reach and greater length.

PART NO. No.75

Length: 600mm
 Weight: 1.82kg
 Max. Span: 250mm
 Min. Span: 0mm
 Max. Reach: 400mm
 Max. Clamp Pressure: 400N



• Small and handy pocket sized • With wire cutter
 • Ideal for gripping and turning rusty and damaged nuts and bolt heads in tight spaces
 • Perfect choice for precision work and delicate operations in awkward areas

PART NO. No.4S

Length: 100mm
 Weight: 0.08kg
 Max. Span: 28mm
 Max. Reach: 13mm

PART NO. No.5S

Length: 125mm
 Weight: 0.17kg
 Max. Span: 35mm
 Max. Reach: 19mm

PART NO. No.6L

Length: 150mm
 Weight: 0.185kg
 Max. Span: 65mm
 Max. Reach: 46mm

For clamping and safe handling of all kinds of work-pieces in bench or machine vices

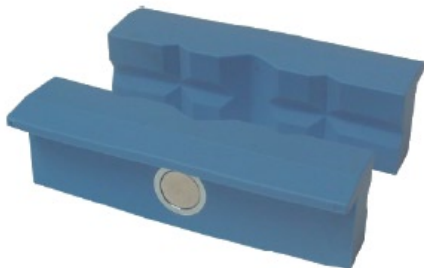

MAGNEFIX PUP

Polyurethane jaws with grooves
 100mm

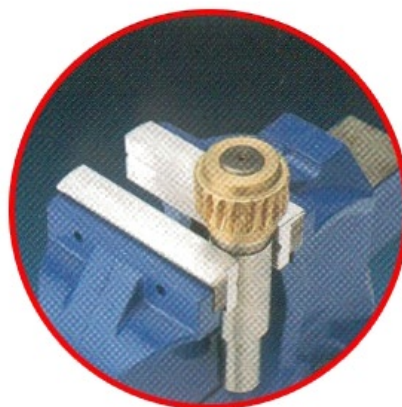

Magnetized attachment to vice jaws



MAGNEFIX PUF

Polyurethane jaws with cross serrations
 100mm